

PID-7418

PID-7418 Label was specially designed for use in pallet And Item-level tracking applications. It can be applied to a wide range of non-metallic objects, making it suitable for use in various other applications like warehouse management, asset tracking, inventory management, box level Tagging, etc.

It performs well on various non-metallic objects, including plastic or cardboard cases & PC surfaces, making it ideal for Retails & multiple industrial applications.

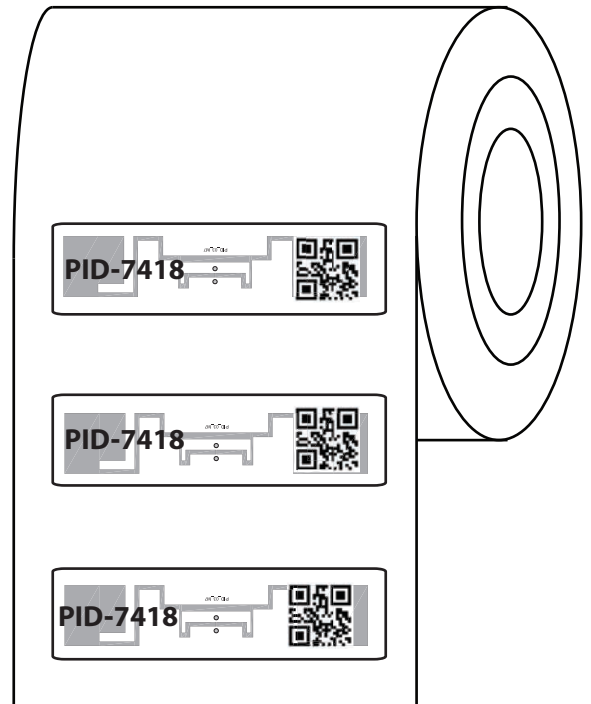

Applications



Asset Management



Retail Management



Warehouse Management

Order Information

Part Number	IC Type	Memory Configuration
RFL-140201-GLOBAL (Polyster) RFL-140202-GLOBAL (Paper)	Impinj Monza M730	EPC Memory - 128 bits
RFL-140501-GLOBAL (Polyster) RFL-140502-GLOBAL (Paper)	NXP Ucode 9	EPC Memory - 96 bits



Electrical Specifications

Operational Frequency	FCC: 902-928MHz ETSI: 865- 868 MHz
Interface Protocol	ISO 18000-63 and EPCglobal Gen2v2
Chip Type*	Impinj Monza M730
Memory Configuration	EPC Memory - 128 bits
Data Retention	10 Years
Write Cycle Endurance	100,000 cycles
Read Range**	upto 18 Meter

Product Characteristics

Die Cut Size	74.0 X 18.0 mm / 2.91 X 0.70 in
Antenna Size	70.0 x 14.0 mm / 2.75 x 0.55
Front Material	Polyster/Paper
Packaging	Reel core inner dimension: 76.2mm/ 3" , 5000pcs/roll
Attachment	Adhesive
Yield	100 %

Environmental Specifications

Operating Temperature	-40 to +85 °C
Storage Temperature	-40 to +85 °C
IP Rating	IP67

Drawing of Product

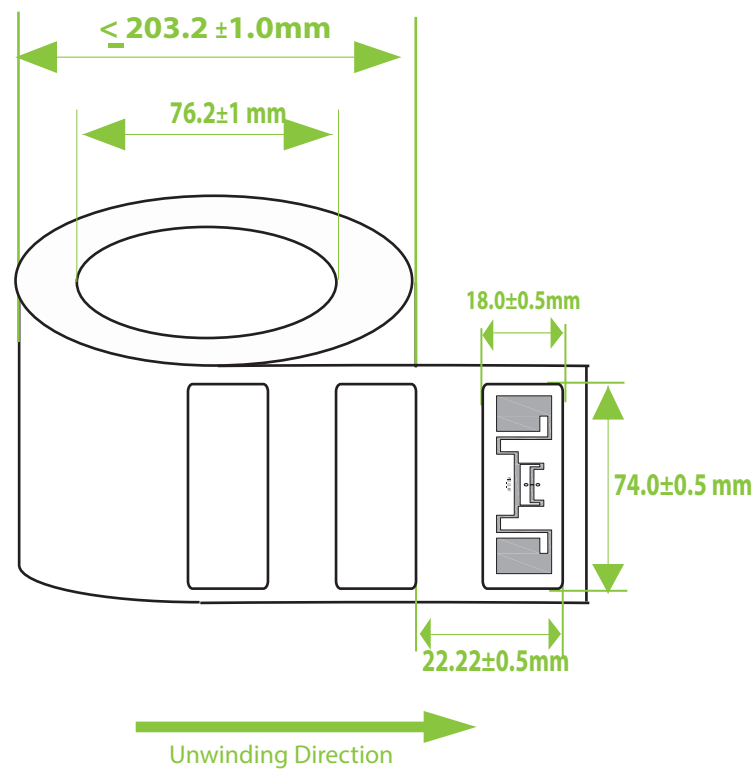

Personalization

- Customer specific encoding of EPC
- Customised printing of logo, text, barcode etc

READ RANGE GRAPH

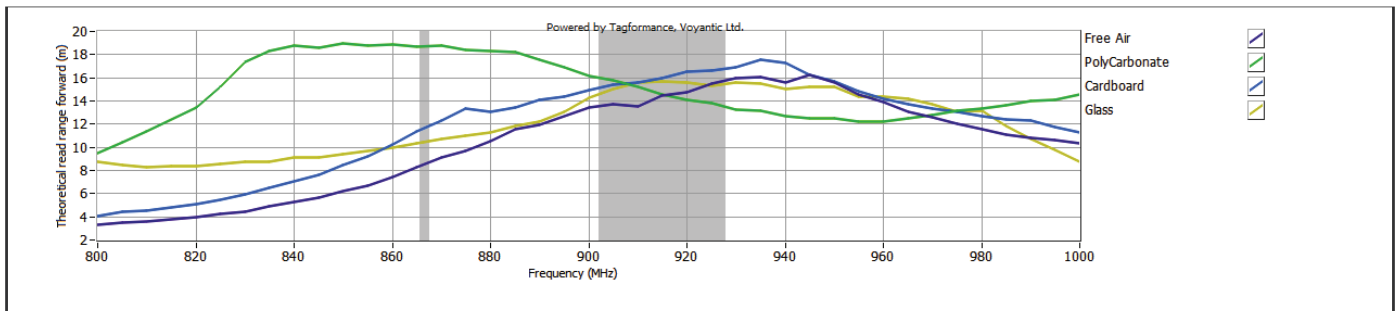

PID 7418 - RF performance(M730)

** The indicated read range values are measured in our laboratory testing environment, where antennas with optimum directivity are used with maximum allowed operating power. Different surface materials and environments may exhibit different results.



www.perfectid.com



Sales@perfectid.com